



# Creating Legacies Through Art: Take an ART Journey





## Table of Contents

- i – iii** Preface
- iv** Glossary
- 1** Snowflakes and what they can do when they stick together!
- 2** Migrating Butterflies
- 3** Curtain Raiser: Put on a Play
- 4** It's about time: Watches
- 5** Singing with the Birds
- 6** Write Your Own Fable
- 7** Paper Forest
- 8** Chinese New Year Celebration
- 9** Save the Frogs: Hop, Jump and Swim
- 10** Out of this World Space Travel
- 11** Be a Star and Shine!
- 12** The Pizza Project: Conversations about Healthy Eating
- 13** Flowers Can Talk
- 14** Everyone is a Winner: Create Your Own Board Game
- 15** The Courage to Fly: Bird Nest
- 16** Take Flight: Wings
- 17** Eye of God (Ojo de Dios)
- 18** Hide and Seek with Masks
- 19** Send Yourself a Message
- 20** Swim with the Fish
- 21 – 24** Appendix - How to Fold Pages



**Use this space to create your own art map!**



# Creating Legacies through Art: Take an Art Journey

## Preface

We are pleased to present *Creating Legacies through Art* to take you on a journey to transform everyday materials into art, to explore the intersections of art with nature, literacy, technology, theater, and music, and to learn how art can express your core values. Throughout this journey, we invite you to reflect on the legacy that can be created through art.

## How this Book Came About

In 2013, Art Sphere Inc. (ASI) responded to the John S. and James L. Knight Foundation's Arts Challenge for innovative projects that would engage and enrich Philadelphia's communities. ASI has always been concerned about the lack of access to and cutbacks in funding for the cultural arts in the inner city. In response, we developed this book of free art lesson plans for children to stimulate and inspire creative thinking. Each art project is outlined with easy-to-follow instructions and can be completed with low-cost or "found" materials. The printed book is supplemented by a database on ASI's website ([www.artsphere.org](http://www.artsphere.org)) with additional art lessons that can be downloaded by teachers and families.

The projects in this book, which have been tested in Art Sphere workshops and in schools, at public events and with diverse audiences, are designed to be easy enough for a parent or a teacher with no art training to teach to others. All the projects can be completed in an hour or less and are intended for children from preschool to 6th grade.

*Follow your creativity and make art that goes beyond where the path leads so you can leave a trail to inspire others to express themselves, too!*

## How to Use this Book

Not everyone learns the same way. Some people are more visual, some more musical, some more mathematical. Our "Trail Maps" include symbols depicted in a "road sign" at the top of each page and indicate the different learning styles to be found in each project. By pointing out the different ways that a project can be approached, parents and teachers can guide their children to their individual paths to artistic success and ways to express their unique creative voices. The different learning styles and the symbols used to represent them in this book include:



**Literacy and Verbal-Linguistic**  
(using words effectively)



**Recycling and Naturalistic**  
(responding to nature)



**Technology and Logical-Mathematical**  
(reasoning, calculating)



**Health and Intra-personal**  
(understanding one's own interests, goals)



**Theatre and Bodily-Kinesthetic**  
(using the body effectively and creatively)



**Musical-Rhythmic**  
(sensitivity to rhythm and sound)



**Multicultural and Interpersonal**  
(understanding, interacting with others)

<sup>1</sup> These learning styles are based on Howard Gardner's discussion of types of intelligences. For more detail, see: Howard Gardner, *Frames of Mind: The Theory of Multiple Intelligences* (New York: Basic Books, 1983).

The lesson plans also are more than just making art objects. They incorporate ideas such as compassion, respect for nature, healthy eating, cooperation, and other ideas for living in a way that contributes to a civil society. The pages are laid out as if you and the class are taking a journey:

- **Your Destination** – summarizes the outcome
- **Travel Kit** – list of materials you will need to make the object
- **On the Path** - ideas and directions for each child to make his/her own object and ideas for exploring the meaning of each object
- **Group Tour** – how to transform the individual process into an interactive and collaborative group experience
- **Extend your Journey** – vocabulary, helpful references, and links to explore additional ideas

The lessons can be used so that each child creates his/her own individual piece of artwork. They also provide ideas for collaborative group projects to create a whole new visual environment. For example, in the Be a Star and Shine lesson plan (#11), if an entire class or group of children each makes a paper star and then the group puts them all together on a wall, they can design a new constellation. From there, the children could give the constellation a name or craft a story about the stars or learn more about how stars are

formed — the possibilities are endless! In the process, not only has the group created an art installation, but they also have learned about the power of creativity and what can be accomplished through teamwork.

Knowing that links sometimes become inactive or are changed is beyond our control and we apologize for the inconvenience. Please check our blog (<http://www.artsphere.org/wp/category/lesson-plans/>) and Instagram (<https://instagram.com/artsphereinc/>) for more suggestions on creative art projects. All the referenced links in this book have been checked for accuracy.

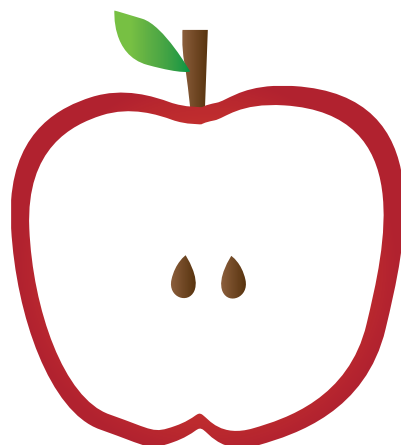

## Thank You

This book would not have been possible without the participation of many talented and dedicated volunteers and supporters. I would like to thank the Knight Foundation for their support, encouragement and for believing in Art Sphere's work with low-income youth.

My thanks also go to Judy Yellin and Ann Kirschner for their collaboration, editing of the lesson plans and invaluable suggestions. I also want to single out Blú Lotus Studio LLC for their hard work on the lively and well-crafted layout and design, Tara Betts for creating our printable handout version of this book and mother and daughter team Barb Hauck-Mah and Rebecca Mah for work on the glossary and hand-drawn elements that also can be found at <http://artsphere.org/creating-legacies-through-art/>.

Many volunteers also provided their time and expertise for which I am very grateful: Anandi Black, Kaliyah Bledsoe, Andy Brunner-Brown, Kashief Butler, Grace Canaan, Candice Carroll, Kadene Chin, Michael Clemmons, Peter Cortner, Danica Cotov, Dianne Cuneo, Brianna Cunningham, Brittany Cunningham, Alysia Davis, Kip Deeds, Jing Du, Frank Everett, Stephanie Gonzalez, Sarah Gregory, Mary Hager, Claire Harte, Michael Haviland, Victoria Hultgren, Ksenia Ilna, Pat Irwin, Ayashe Jamison, Cherina Jones, Serena Kao, Shelby Kehoe, Esther Kim, Christie Keller, Dianne Krasney, Gabriella Latona, Elena Levitan, Jeremiah Lewis, Patrick McCool, Gabby Mora, Bob McCullough, Blair Nakamoto, Sara Napoli, Tricia Olivia, Joseph Pecora, James Porter, Amber Reed, Lenore Romas, Chris Sauerwald, Dinah Schuster, Avery Stern, Bryan Suchenski, Judith Vazquez, Felecia Weaver, Destiny Wimes, Muyan Zhang, Ning Zhang and Nancy Zongyi Zhao. A special thank you to our Board of Directors: Erica Bettwy, P.J. Hakim, Subrata Mukherjee, John Groenveld, and Tiffany Mercer-Robbins. I am also blessed by many others for their support of our work these 17 years and especially my husband, Frank Cellucci, who encourages my creativity.

Enjoy this book and create your own legacies!

Best Wishes on Your Journey,



Kristin Groenveld, Founder and Artistic Director  
Art Sphere Inc.

**Share the artwork you make and your thoughts about the lesson plans and let others know about our free online version of this book:**

**#takeanartjourney**

**#creatinglegaciesthroughart**

**#loveartsphereinc**

# glossary

**This glossary of art, social and scientific terms presents basic definitions to help guide your Art Journey whether you are a student, parent, teacher, volunteer or other art enthusiast.**

**Abstract art** - Does not represent the world exactly, but uses shape and color to explore new ways of looking at the world.

**Asymmetry** - No balance or equality between two parts of something,

**Backdrop** - Painted cloth hung at the back of a theater stage as part of the scenery.

**Camouflage** - Hide something by coloring or covering it to look like its environment.

**Collage** - Art made by gluing pieces of different materials onto a flat surface.

**Color mixing** - Mixing primary colors (red, blue and yellow) in different amounts to create colors.

**Composition** - How the parts of something are put together.

**Contrast** - Amount of difference between light and dark colors.

**Crease** - Fold in paper or fabric made by heat or force.

**Cylinder** - Solid figure shaped like a can with two parallel circles joined by a curved surface.

**Diagonal** -Joining one corner to the opposite corner of a rectangle shape with flat sides.

**Dilute** - Make thinner by adding a liquid such as water.

**Graphic** - Describes visual and writing arts such as printing, photography and design.

**Hue** - Particular color or shade.

**Illustration** - Drawing that explains or adds to a story.

**Mandala** - Geometric figure representing the universe in Hindu and Buddhist religions.

**Mobile** - Art made of pieces that are connected by wire or string and hung.

**Mono-printing** - Process that makes one print of an artwork on paper.

**Mural** - Large picture painted on a wall or ceiling.

**Origami** - Japanese art of folding paper into artistic shapes.

**Osmosis** - Movement of a liquid through a membrane until the liquid is equal on both sides.

**Pattern** - Grouping of shapes that is repeated over and over.

**Plumage** - Feathers of a bird.

**Proportion** - Part of a whole measured by comparing the size of one thing to another.

**Public art** - Works of art created to be displayed in an open space that the public can visit.

**Radial design** - Circular design with lines drawn from its center.

**Radial symmetry** - Plant or animal parts in balance around the body's center.

**Relief** - Picture in which the design is raised slightly above the background.

**Semicircle** - One half of a circle.

**Stellar spectrum** - Method for classifying stars based on their temperature and energy.

**Stencil** - Sheet cut in a pattern on which paint or ink are spread to create a print.

**Stylized** - Design that follows a created pattern.

**Symbolic color** - In some cultures, colors have special meanings. In China, red means happiness.

**Symmetry** - Both sides of an object are centrally balanced in size or shape.

**Texture** - Feel or look of the surface of an object.

**Typography** - Producing printed materials made with type.

**Warm and cool colors** - Colors on opposite sides of the color wheel create opposite feelings, such as warmth for red and coolness for blue.

# SNOWFLAKES

and what they can do  
when they stick together

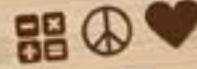

## your destination

Snowflakes are each uniquely designed by nature. They are fragile and quickly melt in your hand. But when they're grouped together, snowflakes can be made into things like snowmen, igloos and snowballs. Make individual paper snowflakes that are mounted on colored paper and passed around the room so that children can add words of encouragement to each other. When all the snowflakes are grouped together, they show team spirit and collaboration.

### travel kit:

- White paper squares 8 1/2" x 8 1/2"
- Markers and glue
- Pictures of snowmen, igloos & snowflakes for reference
- Construction paper with the quote, "Snowflakes are fragile creations, but look what they can do when they stick together."

## group tour Make a Snow Scene

- Write the quote "While each snowflake is beautiful, it takes more than one snowflake to make a snowman" on the blackboard or on the mural paper.
- Transform a wall (using acrylic paint) or create a paper mural (using tempera paint) by arranging the snowflakes as stencils on the surface. Take small sponges and dab blue paint on white paper or white paint on blue paper. Remove the stencil for positive or negative effect.
- Transform the room by tying snowflakes to string on hangers to create paper mobiles.

## on the path Create your own Snowflake

**Step 1** Show a finished snowflake. Hand out at least 2 white squares to each child.

**Step 2** Demonstrate how to fold and cut the snowflake: Fold paper in half diagonally to make a triangle. Then fold that triangle in half two more times to make a smaller triangle. Shapes can be drawn with a marker before cutting. Cut different shapes into the folded edges of triangle while leaving some areas uncut. The edge with no folds can be cut. Unfold paper to reveal finished snowflake.

**Step 3** After cutting the snowflakes, glue them to the construction paper. Have children write their names on the back of each paper.

**Step 4** Discuss what qualities make a person unique. Help children brainstorm encouraging things to say to others and to themselves.

**Step 5** Have the group pass their papers around and ask them to write something kind on the back of each person's paper. Younger children may need more guidance with this step.

## extend your journey

**Learn new vocabulary:** collaboration, empathy, mobile, mural, symmetry, uniqueness, unity

**Find resources and visual aids for different types of snowflake formations:**  
<http://ngm.nationalgeographic.com/2011/02/snowflakes/vintage-photography>

**Learn more about snowflakes and crystals and how they're formed:**  
<http://www.its.caltech.edu/~atomic/snowcrystals/>



# MIGRATING BUTTERFLIES

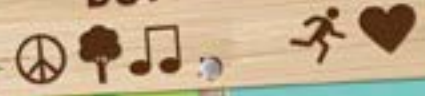

## your destination

Make individual paper butterflies to compare the life cycle, migration, and travel of monarch butterflies through their developmental stages to the challenges of children. Look at the important role butterflies have as pollinators and their habitat needs.



### travel kit:

- Liquid watercolors
- Small plastic droppers
- Bowls for watercolors
- Coffee filters
- Pipe cleaners

**Alternative:** Use markers or diluted watercolors that can be dabbed on with brushes or applied using a spray bottle

## group tour Make a Butterfly Exhibit

- Build a tissue-paper flower garden: <http://www.wikihow.com/Make-Tissue-Paper-Flowers>
- Make a mobile: Using a hole punch, make holes in the wings of butterflies and string with yarn to hang from sticks or coat hangers, which then can be hung from ceiling.
- Create a butterfly using teamwork and the concept of symmetry: With one or more partners, cut paper into shape of a butterfly, fold in half, paint designs on one wing, and then fold the wing over to transfer the wet design to the other wing.
- Using a large sheet of white paper, cut out the shape of a glass jar. Next, draw the stages from caterpillar to butterfly on the jar. Make simple origami butterflies by folding a piece of paper in half on the diagonal to create a triangle. Decorate with markers. Attach to a string with a stapler and have the butterflies fly out of the jar.

## on the path Create your own Butterflies

**Step 1** Use the plastic droppers to squeeze watercolors onto a coffee filter or dab with brush. Try dipping the edges of the filter into different colors of paint.

**Step 2** Once the butterflies have dried, pinch the center of the filter to form wings, fold a pipe cleaner in half and twist it around the middle to secure the fold.

**Step 3** Curl the ends of the pipe cleaners to form antennae.

**Step 4** Express yourself through movement by dancing the stages of a butterfly to music: crawl like a caterpillar, hug yourselves into the shape of a cocoon, then break free and pretend to fly around room looking for flowers.



## extend your journey

**Learn new vocabulary:** antennae, color mixing, dilute, habitat, metamorphosis, migration, osmosis, pollinators

**USDA Forest Service, Monarch Butterfly Migration and Overwintering:**  
[www.fs.fed.us/wildflowers/.../Monarch\\_Butterfly/migration/index.shtml](http://www.fs.fed.us/wildflowers/.../Monarch_Butterfly/migration/index.shtml)

# CURTAIN RAISER: PUT ON A PLAY



## your destination

Write a play about a character or characters that succeed through determination and perseverance, and create movable stages out of paper, complete with scenery and puppets.



### travel kit:

- Small ice pop sticks
- Pipe cleaners or string
- Paper
- Colored pencils
- Scissors
- Glue



## on the path Create your own Stage With Actresses & Actors

**Step 1** Draw a large letter H on a rectangular piece of paper held vertically, leaving a 2" margin outside the lines of the letter. Fold the paper along the center of the H and cut along this fold just to the outside lines of the H.

**Step 2** Now cut along the inside of the long lines of the H. Fold the two center rectangles of paper like an accordion to create paper curtains on either side of the stage. Fold the lower section of the paper up to create the stage floor and reinforce with tape to make it stand by itself. Decorate the curtains and stage floor.

**Step 3** Draw the figure of a leading character on paper and color it. Cut out the character and glue feet first onto the top of a small ice pop stick so it can be moved across stage without the hand being seen.

**Step 4** Play with the creation: Name the character, give it a voice and a story. Create a cast of characters and roles to expand the story. Design imaginative scenery props and backdrops. Write the script out so that the play can be done again. With younger children, it works best to tell the story first and then write it down.

## group tour Create a Performance

- Perform for a live audience or make a video.
- Have a group discussion: What elements are important in making a good story? Consider the theme of perseverance in relation to the video clip from from <https://www.youtube.com/user/StorylineOnline>
- Did the character(s) succeed in the end? How many obstacles did the character(s) overcome?

## extend your journey

**Learn new vocabulary:** backdrop, characters, compassion, dialogue, downstage, obstacles, perseverance, plot, scenery, script, set, stage, upstage

**Listen to children's books read by famous individuals:**

<http://www.storylineonline.net/>

**Watch clips of acting exercises for kids:**

[https://www.youtube.com/watch?v=8t-7fDMA\\_dQ](https://www.youtube.com/watch?v=8t-7fDMA_dQ)

and practice acting exercises in front of a mirror or with friends

# IT'S ABOUT TIME: WATCHES



## your destination

Make paper watches and document the most important time/hours of your day to introduce responsibility. Consider different activities that might happen during each hour and why keeping track of time is important.



## group tour

Transform a Room  
into a Time  
Travel Machine

- Draw a picture illustrating your favorite time of day.
- Label one wall for 12 noon, one wall for 3 p.m., one for 6 p.m. and one for 9 p.m. Hang the pictures showing the favorite times of day on the appropriate walls. Leave spaces in between representing times in between the chosen hours. Have the group stand in the center of the room and then "time travel" to someone else's favorite time of day.

## travel kit:

- Construction or white paper
- Scissors, glue, markers
- Crayons or colored pencils

## on the path Create your own Watch

**Step 1** Cut out a long rectangular strip of paper for a watchband and a circle of paper for the clock face.

**Step 2** Choose 3 or 4 favorite times of the day and write the numbers on the clock face. Decorate the wristband and watch face with images to illustrate the favorite times of the day.

**Step 3** Glue or tape wristband and watch face together.

## extend your journey

**Make a human sundial:** In a sunny place, draw a 10 foot diameter circle by holding a piece of 5 foot string attached to chalk to the ground. (Mark this holding point as center of circle.) Mark the ground while walking with the string tightly extended. Stand in the center at the 12 noon point. Put a rock or mark with chalk for each hour on the edge of the circle. Go back and check the times. (Note: each month you will need to adjust your central standing position for a shadow to accurately tell the time.) <http://www.crayola.com/lesson-plans/human-sundial-lesson-plan/>

**Learn new vocabulary:** document, illustration, responsibility, sundial

**Make an individual sundial by making a hole in the center of a paper plate and then putting a straw through the hole:**

<http://www.nwf.org/kids/family-fun/crafts/sundial.aspx>

**Look at and discuss this chart of how historical figures (e.g. Benjamin Franklin) spent their days:**

<http://infographwetrust.files.wordpress.com/2014/03/creative-routines-edit3.png>

**Explore the history of sundials, watches and telling time:** <https://explorable.com/sundials>

<http://www.hautehorlogerie.org/en/encyclopaedia/history-of-watchmaking>

**Listen to travel to another dimension:**

A *Wrinkle in Time* by Madeleine L'Engle  
<https://www.youtube.com/watch?v=uTjxYMXW>  
CmQ&list=PLaVoeXsqKHiP4AvLrO-e6Wx-vSDaQ46P



# SINGING WITH THE BIRDS



## your destination

Make a hand puppet using a single sheet of paper folded like an "origami fortune teller." Develop a voice, a song and a story for the puppet. Practice intra-personal skills by creating an identity by naming, creating a voice and developing actions for the puppet. Practice inter-personal skills by using the puppet in small groups to create skits, songs and performances for others. This project also uses mathematical skills by exploring symmetry through folding.

### travel kit:

- Square piece of white paper
- Pencils & markers
- Scissors
- Tape & glue

## group tour

### Create a Performance

- Create a stage set by taping two sheets of paper to hang off a table as curtains. In groups of 2 or 3, create a story and or song and any needed props. Sit under table to perform.
- Songwriters often work together to create a message for an audience. If you were a singer or songwriter what might be your message?

## on the path Create your own Hand Puppet

**Step 1** This puppet is made using the folding method to create an "origami fortune teller." Fold a paper square in half on a diagonal to create a triangle and then unfold.

**Step 2** Fold each of the four corners to the center point. Then repeat.

**Step 3** Carefully put thumb in the opening on the bottom and fingers in top opening. Fold in half diagonally, making fingers and thumb meet inside hand puppet. Draw beak and eyes. The opening will be the mouth. Color with markers. On a separate piece of paper, draw feathers and then color, cut and glue to puppet.

**Step 4** Make a stage, curtains and props for the puppet, personalizing the origami shape with color and added feathers. Ask each child to sing his/her own bird song.

**Step 5** Draw a line on paper. Is it bumpy or does it get darker as it goes across the page? Express yourself through song and sound by making a sound that imitates the line or make lines on paper that imitate your favorite sounds.

**Step 6** Do you have a favorite singer and why? Singers have unique names, personalities, styles and material they perform. Point out that each one has a different personality or message that they express.

## extend your journey

**Learn new vocabulary:** diagonal, identity, origami, skit, symmetry

**Origami Fortune teller video:** <https://www.youtube.com/watch?v=LdRXrp2CUIs>

**Create your own story:** <http://storybird.com/>

**Birds singing:** <https://www.youtube.com/watch?v=wKhFZPefb64>

## WRITE YOUR OWN FABLE

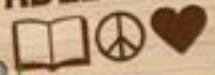

### your destination

Read the classic tale of "The Lion and the Mouse" from Aesop's Fables to introduce the concept of compassion. Make your own books out of white paper and then share meaningful stories with others. Use this project as a way to reflect on something considerate you have done for someone else.

### travel kit:

- "The Lion and the Mouse" story
- White paper
- Stapler
- Crayons, pencils & colored pencils

### group tour

### Create Unique Books Together

- Present the individual stories to the group.
- Make a group book: Fold each page like an accordion. Each person adds his/her own page with a story or illustrations, and attaches the individual page to the preceding page. Display like a screen standing up.
- Make a circle book: Cut a paper circle for each child. Fold paper circle in half and glue back right half of one circle to the back left half of another circle.
- Make an origami book: Fold a square of paper in half horizontally. Fold left to right in half again, fold top to bottom and then left to right again. Unfold to see 8 squares. Fold in half and make a cut in the center of the folded side to the middle (1 square.) Unfold so the cut edge is horizontal. Fold over and push out cut side to make a diamond shape and then pinch sides together to make a folded book.
- Make a heart-shaped book that becomes a mouse: Stack 3 sheets of white paper and one sheet of colored paper for the cover. Fold stack of papers in half and cut into a half heart shape. Staple at the fold. When book is folded, add feet to the crease line, a nose and whiskers to the crease at sharp point and a string for the tail. Add ears, and you have a mouse book.

### on the path Create your own Book and Story

**Step 1** Read "The Lion and the Mouse" and look at how the illustrations tell the story. Think about the theme of the story. Share personal experiences of compassion.

**Step 2** Create a basic book by stacking 3 sheets of white paper and one sheet of colored paper for the cover. Fold the stack of papers in half and then staple along the fold.

**Step 3** Use pencils, crayons, and colored pencils to illustrate the cover. Start by writing the title. Then write "Written and Illustrated by" and fill in your name.

**Step 4** Make up your own version of "The Lion and the Mouse." Discuss how the story might change if it takes place in the city, the zoo or another place, or with different animals.

### extend your journey

**Learn new vocabulary:** classic, compassion, considerate, crease, origami, trust

**Aesop's Fables and The Lion and the Mouse**  
<https://www.youtube.com/watch?v=iPybpc-xuG0>

**Teaching empathy with Aesop's Fables**  
<http://gec.kmu.edu.tw/~lc/ecorner/eBook/Teaching%20With%20Aesop's%20Fables.pdf>

**Origami book:** <https://www.youtube.com/watch?v=vnnA2xsl8M>

# PAPER FOREST



## your destination

Explore the beauty, wisdom, and importance of trees. Perfect for the official change of seasons. Celebrate how each living thing has its own time line, such as, trees must lose their leaves in the fall to prepare for winter.

## group tour

Join others to create a forest and build a habitat for animals

- Arrange the trees together to create a forest.
- Fold rectangular paper in half and draw an animal using colored pencils. Cut out so they are symmetrical and can stand on their own. Write a short story: What could the wind be saying to the trees about the animals of the forest?



## extend your journey

**Learn new vocabulary:** crouching, habitat, impact, team building, texture

Explore why leaves change colors and drop off the tree in the fall

**Connecting with the forest:**  
<https://www.plf.org/family-activities-connect-kids-to-nature-forest>

**See an ancient redwood tree:**  
<http://ngm.nationalgeographic.com/redwoods/gatefold-image>

**Listen to Will Hale sing "The Acorn Song":**  
<https://www.youtube.com/watch?v=K-B0C6gaS9s>



## travel kit:

- Brown paper bags (lunch size or larger)
- Scissors
- Glue
- Colored tissue paper or colored construction paper
- Colored pencils

## on the path Create your own Tree

**Step 1** Cut paper bag into half-inch-wide strips. Start at the opening and cut halfway down the bag.

**Step 2** Open bag and stand it up.

**Step 3** Hold base of bag with one hand and twist the middle of bag to create the trunk of the tree.

**Step 4** Twist the bag strips together in twos to create branches.

**Step 5** Tear colored paper or tissue paper into tiny pieces and glue them all over the branches of the tree. Or hang triangular white paper icicles for a winter scene.

**Step 6** Discuss the seasons, nature and our impact on them. What is it like outside? What season is it now and what season is next? What do trees look like in the spring? Do we need trees? Do animals need trees? Have you ever heard someone say trees are wise? What trees can you identify and how?

**Step 7** Act out how a tree grows by crouching down and slowly "growing" into a standing position with arms and hands out. Look at photos of trees that are local to your area.



# CHINESE NEW YEAR CELEBRATION

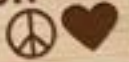

## your destination

Learn the animal of your birth year that is associated with the Chinese calendar, while gaining an appreciation for Chinese-American culture and the 15 Days of Celebration that take place every Chinese New Year. Make a Chinese lantern to complete the celebration.

### travel kit:

- Red and gold paper
- Pencils, markers
- Scissors & glue
- **Alternative materials:** Use white paper, black ink or watercolor, and brushes.
- **Optional:** String for hanging lanterns, coloring materials such as markers and crayons. Tape lanterns to flashlights in order to illuminate the creations.
- Sample line drawings of animals represented on the Chinese calendar

## group tour

### Transform the Room into a Lantern Festival

— Make the room into an art installation.

- Talk about cultural uses and meanings of the Chinese lanterns. When are these lanterns used? What do they symbolize? How do children in China use these decorative lanterns?
- Fold a piece of paper lengthwise into a rectangular shape.
- Use scissors to cut slender lines along the entire crease of the paper. (These cuts should be about  $\frac{1}{4}$  to  $\frac{1}{2}$  inch apart and should cover only half of the paper's width.)
- Open paper and flip inward so that it forms a bowl shape. Punch two holes on the opposite sides on the top and pull a string through the holes to make a hanging lantern.
- Ask the group to talk about their favorite holidays. If they could create a new holiday, what would it be? What types of decorations would they want for their holiday?

## on the path Create your own Animal

**Step 1** Using the Chinese calendar and the year of your birth, identify your animal. Identify the current year's animal.

<http://www.chinesenewyears.info/chinese-new-year-calendar.php>

**Step 2** Practice drawing your animal with a pencil. Then go over the outline of the animal with black marker, black ink or watercolor.

**Step 3** Use scissors to cut gold paper and glue basic shapes onto red paper to create a frame.

**Step 4** Learn the characteristics of your animal and also invent some of your own.

**Step 5** Draw the word "friendship" in Chinese. <https://www.youtube.com/watch?v=gMTJ4FnBN7Y>



## extend your journey

**Learn new vocabulary:** celebration, contrast, give and take lines, illumination, lantern, stylized, symbolic color

Include important symbols such as a bowl of oranges, the phoenix, dragon, panda, fans, lanterns and Chinese calligraphy in making art for this holiday season.

**See how Chinese lanterns are used during traditional celebrations and learn the history of the lantern festival:** <http://www.chinahighlights.com/festivals/lantern-festival.htm>

**Watch a lantern festival:** <https://www.youtube.com/watch?v=RFcGvmFtR-s>



## travel kit:

- 1 (8.5" x 8.5") square each of green paper and pink tracing paper
- 1 (4" x 4") square each of pink, yellow and white paper
- Googly eyes or white paper cut in circles
- Scissors & markers
- **Optional:** paper towel tubes, pipe cleaners, pebbles or rice

## on the path

### Create your own Origami Frogs & Lily Pads

**Step 1** Fold green paper in half on a diagonal to make a triangle. Position like a pyramid with top most point being the frog face and the opening the frog mouth.

**Step 2** Fold side corners to the center and back out again to create feet.

**Step 3** Secure eyes with glue to the frog. Add a red tongue, draw flies on the tongue, and cut and glue to frog. Decorate triangle frog body with patterns.

**Step 4** Make lily pads by cutting off the four corners of the square to create a circle. Cut a triangular pie slice out of green circle. Draw lines for leaf veins.

**Step 5** Fold the pink square in half twice to form a square. Cut open corners in a zigzag for flower petals.

**Step 6** Fold yellow and white squares in half twice to form a square. Cut lines toward center from open corners.

**Step 7** Nest and glue the white and yellow papers inside the pink paper to create a layered flower.

**Step 8** Draw half a glass jar on a piece of white paper folded into a rectangle. Cut out the jar shape.

**Step 9** Draw water on vase and add eggs and tadpoles and frogs in different stages.

## extend your journey

**Learn new vocabulary:** amphibian, ecosystem, multicultural, radial symmetry, tadpole

**Listen to musical frog calls:** [https://www.youtube.com/watch?v=M02\\_dnl9zCA](https://www.youtube.com/watch?v=M02_dnl9zCA)

<https://www.youtube.com/watch?v=u5quYQ4JH6c>

**Watch frogs:** <https://www.youtube.com/watch?v=oMFXQsaT274&feature=youtu.be>

**Frog facts:**  
<http://www.defenders.org/frogs/basic-facts>  
<http://www.kiddyhouse.com/Themes/frogs/>

**Frog story from Australia:** <https://www.youtube.com/watch?v=0y3Ta5xcKV4>

## your destination

Frogs can be seen as multicultural symbols since they can be found on almost every continent in the world (except Antarctica). Studying frogs also provides insight into the health of ecosystems for scientists worldwide.

## group tour

### Transform the Room into a lily pond

— and create a rain dance instrument.

- Add flowers and frogs on the floor and walls.
- Some frogs live in the rain forest and need lots of water.
- Make a rainmaker to create rain for your frog: Take a paper towel tube and tape paper over one end. Add a curled pipe cleaner inside the paper towel roll so that it catches whatever goes inside. Put in pebbles or rice and close this end of the tube by folding in the edges of the tube. Dance with your rainmaker! <https://www.youtube.com/watch?v=Pfvzc6LZTMY&list=UUTCvLsVBt-Oc7g9PakgudwQ>
- Use chalk and transform the sidewalk with drawings of frogs and lily pads.





# OUT OF THIS WORLD: SPACE TRAVEL



## your destination

Decorate your own spaceships that can be launched with a straw. Astronauts have to trust each other in order to persevere through space together.

## group tour Transform Room into outer space With a 3-D Sun

— View images of the sun and solar flares. Create 3-dimensional suns with handprint cutouts to represent solar flares.

- Trace and cut out hands on yellow and orange paper.
- Make handprints using yellow, orange and white tempera paint on plastic plates. Let dry and cut out.
- Glue the hands around the front edge of one paper plate.
- While waiting for glue to dry, decorate the back of the second paper plate.
- Decorate the back of the first paper plate. Glue the undecorated front sides of the two paper plates together.
- Punch a hole on outer edge of plate and tie yarn through the hole to hang their suns.
- Discuss – How does the sun help earth? Why is the sun important to the solar system?
- What planets have spaceships enabled us to explore? How do astronauts train? How long do spaceships stay in outer space?

## travel kit:

- Drinking straws
- Yarn or ribbon
- Markers, crayons & colored pencils
- Hole-punch
- Tape, glue, stapler
- Colored construction paper
- Paper & plastic plates

## on the path

### Create your own Paper Spaceship Rockets

**Step 1** Draw a spaceship on a piece of paper and decorate the outside.

**Step 2** Staple paper together lengthwise to form a cylinder. Use tape to close the top end of the ship.

**Step 3** Trace and cut out a circle for the top of the ship (which you can also decorate). Creating a small top for the ship makes it easier to launch.

**Step 4** Staple circle into a cone shape and then staple it to ship. Close the entire top hole with tape so it will be easier to launch.

**Step 5** Punch 4 holes on the bottom of the rocket.

**Step 6** Tie yarn to the bottom of the spaceship.

**Step 7** Use a straw to blow into spaceship to make it fly!



## extend your journey

**Learn new vocabulary:** astronaut, cylinder, gravity, NASA, persevere, rocket, solar flare, solar system, technology

**Spaceship photographs, mazes and facts at NASA kids:** [http://www.nasa.gov/audience/for\\_kids/kidsclub/flash/#.VMEDfCi13Vs](http://www.nasa.gov/audience/for_kids/kidsclub/flash/#.VMEDfCi13Vs)

**Family guide to the sun:** [http://www.spaceweathercenter.org/resources/04/fam\\_guide\\_sun.pdf](http://www.spaceweathercenter.org/resources/04/fam_guide_sun.pdf)

**NASA image of the Day provides images of space, planets, and ships:** <http://www.nasa.gov/multimedia/imagegallery/iod.html#.VM>



Using individual stars, make an original constellation to introduce the concept of respecting differences. Different cultures have different stories for the constellations because everyone sees things differently.



### travel kit:

- White paper
- Crayons
- Large blue paper
- Double-sided tape
- Scissors



### group tour Make your own constellation

— and transform the room into a night sky

- Tape the paper stars onto blue paper and hang on wall wherever you choose.
- Connect the dots: After at least 5 stars are posted, step back and draw on paper what you see on the wall. Create your own constellation from the star arrangement by connecting the stars with lines. Collect group constellations and read constellation creation stories.
- Squint at the stars and ask, "Which star do you think is the coolest or warmest? The blue stars or the red giants?" Write a story about constellations to deepen interest in individual star creation.

### on the path Create your own Star

- Step 1** Make an origami star finder for each month to depict the night sky. Instructions can be found at: <http://spaceplace.nasa.gov/starfinder/en/>
- Step 2** Make paper stars by folding a piece of square paper into 8 equal triangles. Draw lines on open sides inward for the star arms before cutting. Cut arms of the star (similar to making a paper snowflake.) Color or decorate the paper stars in blue, white, yellow, red or a combination of colors.
- Step 3** Squint at the star to determine which color is strongest even if many colors were used.
- Step 4** Like an astronomer, determine the age of your star according to the stellar spectrum chart: <http://oneminuteastronomer.com/708/star-colors-explained/>
- Step 5** Discuss how stories of stars and constellations represent different things to different cultures.

### extend your journey

**Learn new vocabulary:** astronomer, constellation, curiosity, mass, red giants, stellar spectrum, warm and cool colors, volume

**NASA for students:** <http://www.nasa.gov/audience/forstudents/>

**Make a paper star finder and use this chart outside to identify the stars you see in the night sky:** [http://www.pbs.org/soptv/400years/files/resources/Making\\_Using\\_Family\\_Star\\_Finder.pdf](http://www.pbs.org/soptv/400years/files/resources/Making_Using_Family_Star_Finder.pdf)

#### Learn about how different cultures interpret stars and constellations:

- **Greek mythology and constellations:** <http://www.wvu.edu/skywise/greek/myth.html>
- **Native American lore about stars:** <http://www.wvu.edu/skywise/legends.html>

- **Catalogue of constellations and the stories behind them:** <http://chandra.harvard.edu/photo/constellations/index.html>
- **Australian lore:** <http://museumvictoria.com.au/pages/6927/stories-in-the-stars.pdf>

# THE PIZZA PROJECT

Conversations about Healthy Eating



## your destination

From a simple paper bag and scraps of colored paper, create a pizza using collage techniques. This group project inspires team building, healthy eating and food safety.



### travel kit:

- Brown paper (large paper bags or butcher paper)
- Glue
- Scissors
- Colored construction paper (use leftover scraps!)

## group tour

### Transform a table into a Pizza Shop

- To make a pizza shop, create a name sign, a logo, a menu with prices, descriptions for different toppings and names for the different kinds of pizza.
- On a paper plate, draw and color one of each of the following: a protein (seafood, lean meat and poultry, eggs, beans, peas, soy products, and unsalted nuts and seeds), fruits (fresh, canned, frozen or dried fruits), vegetables (fresh, canned or frozen vegetables), grains (whole-wheat bread, oatmeal, popcorn, quinoa, or brown or wild rice), and dairy (yogurt, cheese or soy.)
- Make the color wheel with food. For example, red cherries, orange pepper, yellow beans, green peas, blueberries, purple plums.

## on the path

### Create your own Paper Pizza

- Step 1** Take brown paper and cut into a large circle.
- Step 2** Curl edges of paper circle to make a pizza crust.
- Step 3** Discuss favorite pizza toppings. Cut shapes for different toppings. Pizza can have different sections with different toppings like half mushroom and half spinach. Arrange.

- Step 4** Glue on pizza parts.
- Step 5** Cut pizza slice and glue to paper plate.
- Step 6** Identify healthy foods that can make a pizza healthier. Are there different kinds of vegetables that can make a pizza a bit healthier?



## extend your journey

- Learn new vocabulary:** collage, nutrition, pattern, team building, topping
- For information on food safety, recipes, and nutrition:** [www.nutrition.gov/life-stages/children](http://www.nutrition.gov/life-stages/children)
- Kids Health and nutritious recipes from Nemours:** <http://kidshealth.org/kid/recipes/>
- Basic cooking skills and recipes for kids:** <http://www.spatulatta.com/>

# FLOWERS CAN TALK



## your destination

Flowers are a symbol of compassion, beauty and love of nature. People and plants grow together. In this project, you can create your own flower arrangement to honor the famous Philadelphia Flower Show or other local flower shows.

### travel kit:

- 12" x 18" paper
- Glue
- Tempera paint
- Scissors

## group tour Transform your Room into a Flower Shop

- Create a name and a logo for the flower shop.
- Make 3-D paper flowers and wrap in tissue paper. <http://www.wikihow.com/Make-Tissue-Paper-Flowers>
- Draw a greenhouse with potted plants, seed packets and a watering can. Glue on plastic wrap to represent glass.
- Paint a garden landscape of flowers and glue on elements, such as a fence, hose, arbor or trellis cut from newspaper.

## on the path Create a Vase of Flowers

**Step 1** Begin by discussing flowers as symbols of compassion. Flowers are a way to connect to other people's feelings, while also expressing care or concern.

**Step 2** Fold a sheet of white paper in half lengthwise. Draw half a vase on one side of the fold.

**Step 3** Cut through the line at the top and bottom of vase. Push the vase out in the opposite direction to create a pop-up effect.

**Step 4** On a separate piece of paper, draw flowers with stems, using reference material to actual flowers or representing the month you were born. Color in and add detail to the flowers with colored pencils.

**Step 5** Paint half of the vase and while paint is still wet, fold paper in half and press down to transfer decoration to other side of paper using basic mono-printing technique.

**Step 6** Cut out 5 or more flowers and glue them onto the vase to make a collage flower arrangement.

**Step 7** Fold a small piece of paper to make a greeting card. Decorate and write a message on the card that expresses compassion and empathy.

**Step 8** How do you arrange your flowers so your drawing is unique? How are flower arranging and making art similar and how are they different? What does your bouquet of flowers say to someone receiving it?

## extend your journey

**Learn new vocabulary:** arranging, collage, composition, greenhouse, mono-printing, relief

**Discover the symbolic meaning of flowers in Medieval and Renaissance art:**  
[http://artsedge.kennedy-center.org/educators/lessons/grade-6-8/Medieval\\_and\\_Renaissance%20Art](http://artsedge.kennedy-center.org/educators/lessons/grade-6-8/Medieval_and_Renaissance%20Art)

**Japanese Flower arranging:**  
<http://www.ikebanahq.org/whatis.php>

**Flower arranging with videos:**  
<http://www.wikihow.com/Arrange-Flowers>

**Current images of plants in bloom:**  
<http://www.bbg.org/bloom>

# EVERYONE IS A WINNER: Create your own Board Game



## your destination

Create a board game and work together to navigate through life the same way we navigate playing a game. This encourages team spirit, playing fair and respecting differences.



### travel kit:

- 2 sheets of colored construction paper
- White printer paper, graph paper
- Colored pencils and markers

## group tour Play your Game

- Play your game!
- Create paper plate crowns and treasure boxes for everyone because we are all winners if we play the game!
- Each person creates his/her own maze with a pencil, ruler and graph paper. Exchange your maze with another person to fill in the solution. (Graph paper helps with this activity.)

## on the path Create your own Board Game

**Step 1** Tape 2 sheets of rectangular colored construction paper (or thin cardboard) together to resemble a folded game board.

**Step 2** Decide on a theme for your game and decorate the board.

**Step 3** On the edge of one sheet, write the word "start" and on the edge of the other sheet of paper, write the word "finish." Connect the start and finish with square or other shaped boxes for spaces. For example, frogs would have lily pad-shaped spaces to jump through.

**Step 4** On white paper, draw characters to represent the players and cut them out.

**Step 5** Create 4 or 5 cards as "chance" spaces, such as "Move back 3 spaces."

**Step 6** Create paper "dice" by writing numbers on little strips of paper. Then put the paper numbers face down in a pile. Draw from them to determine number of spaces to move on each turn.

**Step 7** Relate the game to goals and obstacles we may encounter every day with discussion of life applications. (Example: the first frog to reach the finish line becomes the prince or princess.)

## extend your journey

**Learn new vocabulary:** goals, navigate, obstacles, quest, theme

**"The Man in the Maze"** <http://www.earthart.org/happenings/kiva/labyrinths.html>

**Symbol of Life maze:** <http://www.warpaths2peacepipes.com/native-american-symbols/symbol-of-life.htm>

**Easy to hard printable mazes:** <http://krazydad.com/mazes/>

**Create a maze online:** [http://puzzlemaker.discoveryeducation.com/AdvMazeSetupForm.asp?campaign=flyout\\_teachers\\_puzzle\\_maze](http://puzzlemaker.discoveryeducation.com/AdvMazeSetupForm.asp?campaign=flyout_teachers_puzzle_maze)

**Watch Anansi at:** <https://www.youtube.com/watch?v=dvsoKem53Ko>

**Read about Anansi, a West African – Jamaican spirit who often takes the shape of a spider and has many adventures:** [http://anansistories.com/Traditional\\_Stories.html](http://anansistories.com/Traditional_Stories.html)

Sing along with story - make an Anansi game.



# THE COURAGE TO FLY: BIRD NEST



## your destination

Build a bird's nest out of recycled and nontraditional materials as a way to talk about courage. Baby birds need courage to fly for the first time.

## group tour Create a Community of Nests

Transform a table into 4 trees filled with bird's nests.

- Wrap the legs of a table in brown paper using tape to hold down the roots on the floor. Extend the twisted paper beyond the tabletop to simulate the upper branches.
- Scrunch green tissue paper on tabletop or add green tablecloth to represent leaves.
- Put the nests on table.

## extend your journey

**Learn new vocabulary:** nest, ornithology, recycled, risk, weave

**Go on a nature walk and look at a real nest to see how a bird weaves the sticks together:** <http://www.flyingwild.org/guide/TheBirdingBeat.pdf>

**Clip of a bird hatching from an egg:** <https://www.youtube.com/watch?v=6JCSNvoQI20>

**To see a nest built:** <https://www.youtube.com/watch?v=9uHYWpfx5Vg>

**For more exercises and nest facts:** <http://www.prbo.org/cms/docs/edu/activity4.pdf>

**Nesting cycle:** <http://nestwatch.org/learn/general-bird-nest-info/nesting-cycle/>

**Nest-making out of trash:** <https://www.youtube.com/watch?v=P1W25sHtUWw>



## travel kit:

- Glue
- Washable brown paint
- Paper plate
- Paint brushes or foam brushes
- Foam stickers of insects, leaves, flowers
- Brown, blue, green, yellow, orange and pink construction paper
- Plastic Easter eggs
- Picture of a bird's nest or an actual bird's nest

## on the path Create your own Birds and Nests

**Step 1** Discuss how a bird makes its nest and what materials it uses, such as twigs, leaves, and sometimes even the trash that it finds. Talk about taking risks in making art or doing something for the first time. What do we notice when the weather changes and it starts to get warm outside? Leaves start to grow and turn green, flowers bloom, birds come out, insects appear, etc.

**Step 2** Paint paper plates brown by placing a small amount of paint in the middle of paper plate and spreading it all the way to the edges. Set aside plate to dry.

**Step 3** Separate one plastic egg; each half of the egg will become the body of a baby bird.

**Step 4** Cut a small yellow square and fold diagonally to create a 3-D beak.

**Step 5** Cut 2 oval-shaped wings from colored construction paper.

**Step 6** Glue a beak and wings to each plastic bird. Set aside baby birds to dry.

**Step 7** Cut strips of brown paper bags or newspaper.

**Step 8** Next take the paper plate and put a small amount of glue in the center of the plate. Spread the glue to the edges of the plate.

**Step 9** Add strips of brown paper or newspaper onto the plate the same way a bird weaves its nest. Add foam stickers of insects, leaves and flowers.

**Step 10** Glue the baby birds to the plates or keep them separate so you can play with them.



# TAKE FLIGHT: WINGS



## your destination

Make wings and learn about the structures of wings while applying life lessons and wisdom learned from the observation of birds. Discuss life situations that require a leader.

## group tour

transform room into an air stream with geese flying south for the winter

- Geese flying south for the winter depend on each other. They need each other in order to complete their goal. Each goose takes turns being the leader and is responsible for the safety of the flock. The goose must be dependable in order to complete the big task of migration.
- Arrange yourselves into a giant "V" shape and follow the bird in front, each taking turns leading when the leader is tired.
- Act out in a group (or groups) as flocks of geese pairing off to assist injured or tired birds.
- Design your own dragon, griffin or sphinx with personal story, and feather wings.

<http://www.mythencyclopedia.com/Be-Ca/Birds-in-Mythology.html>

## extend your journey

**Learn new vocabulary:** alula, covert, hue, plumage, structure, wing

**Look at dorsal wing and feather illustrations:**  
<http://box-jellyfish.deviantart.com/art/Wing-Diagram-173504349>

**Find out why geese fly in a "V" shape:**  
<http://www.loc.gov/rr/scitech/mysteries/geese.html>



## travel kit:

- String or yarn
- Colored construction paper
- Tape and glue
- Marker or pencil
- Hole-punch (optional)



## on the path Create your own Wings

**Step 1** What do we notice when we see birds flying? Wings move fast, look big or small, and sometimes, the movement of the wings creates sounds. Could birds ever move like humans do? How about humans moving like birds?

**Step 2** Look at the diagram of primary, secondary and covert feathers.

<http://www.fws.gov/lab/featheratlas/glossary.php>

Learn the different uses for each type of feather and the essential organization of plumage.

**Step 3** Make a tracing template for the feathers from wing references in order to draw distinct shapes onto construction paper.

**Step 4** With a marker, draw basic wing shapes and trace feather shapes.

**Step 5** Draw a line down the middle of each feather. Then draw little lines from the quill to the end of the feather starting from that center line and out to edges of paper. Angle these lines away from quill and add color details.

**Step 6** Cut out feathers and glue them onto basic paper wing shapes in the general areas of primary, secondary and covert feathers.

**Step 7** Repeat for second wing.

**Step 8** Punch holes along upper edge of feathered wings and add string to tie the wings to your arms.





## your destination

Eye of God talismans (Ojo de Dios in Spanish) have been traditionally created by the Pueblos of New Mexico and the Huichol and Tepehuán Indians of western Mexico. Posted where people walked along a trail, they identify sacred and important places like a spring. They are also used as gifts for children coming of age and as a blessing for a home. Ojos' meanings differ from culture to culture, although traditionally they have four points representing the four directions and four elements: earth, fire, water and air.

## travel kit:

- Two ice pop sticks for each Eye of God
- Yarn (any color can be used) or plastic bags of assorted colors cut into strips

## group tour

transform a room to mark the earth as a sacred place and encourage Recycling 

- Use large found sticks or twigs and have groups work together to weave plastic bags into large Ojos.
- Research the importance of recycling and reusing materials like plastic and make posters about recycling.
- Explore other cultures that also use the symbolism of a square and circles. For example, mandalas from East Indian cultures are a square with four gates containing a circle with a center point. Color plain sand with food coloring or use chalk to make a large mandala on a sidewalk or on a large sheet of paper as a group project.

## on the path

**Step 1** If using plastic bags instead of yarn: Cut plastic bags into long ¼" to ½" wide strips by starting at the handle and cutting horizontally around the bag so that it spirals to the bottom of the bag.

- Traditional meanings for colors: red means life; yellow: sun, moon, and stars; blue: sky and water; brown: soil; green: plants; black: death.

**Step 2** Glue or tie the two sticks together into a plus sign.

**Step 3** Weaving technique that will be used: hold the sticks in one hand and weave the strips or yarn over, under and around each stick. Turn to repeat until each stick has been covered.

**Step 4** When a child loses a tooth or later comes of age, what kind of celebration or gift does he/she receive, such as a Confirmation, Quinceañera, etc.

## extend your journey

**Learn new vocabulary:** mandala, pattern, proportion, Quinceañera, radial design, symmetry, weave

**Watch a God's Eye craft demonstration:**  
<https://www.youtube.com/watch?v=DUX2NgKWJqA>

**See how an artist combined the God's Eye with a mandala:** <https://www.youtube.com/watch?v=qf5euldYEbg>

**Discover more about Huichol art and culture:**

<http://wixarika.mediapark.net/en/index.html>

**Find out about mandalas:**

<http://www.mandalaproject.org/What/Index.html>

<http://en.wikipedia.org/wiki/Mandala>





# HIDE AND SEEK WITH MASKS



## your destination

Create wearable masks from recycled and natural materials. What are the benefits of camouflage? What animals do we know that use camouflage?



### travel kit:

- Paper plates
- Cardboard or heavy paper
- Scissors
- Markers
- Glue
- Items found in nature: leaves, nuts, twigs, etc.
- String or dowels

## group tour transform a room into a stage

- Create a skit about animals hiding. One at a time, the animals sing their songs and come out to be noticed.
- Make camouflage or insect masks with the materials from nature.
- Make multiple masks to teach respect for differences. Discuss how people are like a book and shouldn't be judged by their covers.
- Learn about hibernation and discuss why bears go into hibernation: Cut a paper plate in half, or cut a semicircle out of paper. Cut a door in the middle. Glue the plate or paper face down onto the lower portion of a piece of construction paper to create a forest with mountains on the paper to depict the bear's environment and other animals that hibernate.

<http://www.bbc.co.uk/nature/adaptations/Hibernation>

## on the path Create your own Mask

**Step 1** Go out into the woods or playground and collect leaves, twigs, nuts.

**Step 2** Cut eyes out of a paper plate.

**Step 3** Glue leaves, twigs onto the paper plate.

**Step 4** Attach a string on each side of the mask to tie it around the head. Alternatively, attach a dowel/stick to the side of the mask to hold it in front of your face.

**Step 5** What does it mean to recycle something? Why is it better to use materials we can find in nature than those we buy in a store? What other sorts of crafts could we do with what we find in nature?



## extend your journey

**Learn new vocabulary:** camouflage, evolution, hibernation, recycling, semicircle

**Examples of how animals use camouflage:**  
<http://www.mnn.com/earth-matters/animals/photos/14-amazing-camouflaged-animals/blending-in>

**Insects' camouflage:**  
<http://phenomena.nationalgeographic.com/2013/10/09/evolution-in-color-from-peppered-moths-to-walking-sticks/>

**Acting exercises for kids:**  
[https://www.youtube.com/watch?v=8t-7fDMa\\_dQ](https://www.youtube.com/watch?v=8t-7fDMa_dQ)

**Masks from different cultures:**  
<http://australianmuseum.net.au/masks-from-other-cultures>



# SEND YOURSELF A MESSAGE



## your destination

Decorate a card, make a heart envelope, and write a message inside with special typefaces. Make a word into a sculpture, such as Robert Indiana's Love Sculpture. How can you express yourself differently using different typefaces or writing styles?



### travel kit:

- White paper
- Rulers
- Graph paper
- Crayons
- Glue
- Scissors
- Construction paper

## on the path

### Create your own card & envelope

**Step 1** Fold paper in half and cut half a heart shape along fold.

**Step 2** Fold into thirds in both directions to create an envelope.

**Step 3** Cut a rectangular piece of paper to fit the rectangle at the center of the heart.

**Step 4** Explore writing styles and designs. Watch a video on the history of valentine cards: <http://www.history.com/topics/valentines-day/history-of-valentines-day/videos/valentine-cards>

**Step 5** Write a message on a card and insert into the envelope and decorate envelope. Share the cards with residents of a senior center, or soldiers or other group.



## extend your journey

**Learn new vocabulary:** abstract art, appreciation, asymmetry, graphic, landscape architect, surroundings, typeface, typography

**Explore typography through art:** <http://99designs.com/designer-blog/2013/05/21/25-mind-blowing-typography-art-projects/>

**Get inspired by examples of the many ways letters can be drawn:** <http://cooltext.com/>

**Robert Indiana's Love sculpture:** [http://en.wikipedia.org/wiki/Love\\_\(sculpture\)](http://en.wikipedia.org/wiki/Love_(sculpture))

**Discover what landscape architects do:** <http://www.asla.org/default.aspx>

## group tour

### use words to create a sculpture garden

- Organize teams of "landscape architects" and "sculptors" to transform the classroom into a landscaped garden. Apply the concepts of love for nature and the appreciation of surroundings in an artistic context. Use graph paper (1 inch=1 foot scale) and rulers to lay out the location of the plants, paths and signs.
- Design a sculpture for the garden using a favorite word that promotes respect for the environment. Suggested words for a sculpture design are Peace, Dream, Hope, Create, Art, Now.
- Go on a walk and look at signs, designs and urban art.
- Design posters with special typefaces to promote an appreciation for the city with special typefaces.
- Discussion: Has anyone ever seen the LOVE Park sculpture? What do you notice about it? What's around it? Where do you see signs with words written like this?



## your destination

Design your own underwater scene using stencils while learning about marine life.

### travel kit:

- Acrylic or water-based outdoor house paint (for outdoors) tempera paint
- Sponges or rags
- Paper
- Cardboard (alternative material: used file folders)
- Scissors & tape

### group tour

transform a wooden bench, trash can or wall into public art

- Choose a theme for stencil project and a specific location. Get permission before beginning.
- Decide the appropriate scale so that the stencils will fit the available space.
- Prime the surface with water-based outdoor house paint.
- Brainstorm ideas, pick which stencils to use and choose colors of acrylic paint that work well together. Arrange into an overall design.
- If you have a more complex stencil design, paint each section of a stencil with a different color. Take care so wet paint does not get on the underside of stencil paper.
- To overlay multiple stencils, you will need to plan one stencil paper for each color you use: one for the background, one as a silhouette for shape, and one or more for details or specific area color choices. Wait for each color to dry (approximately 20 minutes).
- Painting with a stencil is easiest with an extra pair of hands holding the stencil flat against surface. Tape can also be used to hold stencil in place on smooth surfaces. Dab paint with a rag or using an almost dry paintbrush, carefully working and pushing paint away from the paper edges.

## on the path *Create your own fish*

**Step 1** Design your own fish on cardboard or manila file folders. Keep the design simple for ease of cutting. Leave a half-inch around the outline to make a stencil. Parts of fish reference: <http://www.dnr.sc.gov/fish/anatomy.html>

**Step 2** Bend a manila folder in half and make center cut to cut out the positive shape. This helps getting started cutting.

**Step 3** Keep the positive fish shape. Hole punch or cut shapes out of this to add colors to the first stenciled image once it is dry.

**Step 4** Holding stencil in place on paper, use small sponges or rags and dab paint inside stencil.

**Step 5** Experiment and personalize your stencil by adding dots or stripes or freehand details. Be creative: a handprint as a tail can be added to an oval stencil to make a fun fish.



## extend your journey

**Learn new vocabulary:** climate, public art, reef, renewable resources, stencil, water pollution

**Explore the anatomy of fish:**

[https://tpwd.texas.gov/kids/wild\\_things/fish/fishparts.phtml](https://tpwd.texas.gov/kids/wild_things/fish/fishparts.phtml)

**Reefs:** <https://www.youtube.com/watch?v=bNucJgetMJE>  
<http://video.nationalgeographic.com/video/atmosphere/underwater-indonesia-atm>

**Water issues:** <http://fishandboat.com/education/catalog/waterpollutionpa.pdf>

**Fish species and classification:** <http://www.fishbase.org/identification/classlist.php>

# Appendix

## Folding Basics

Making a rectangle into a square

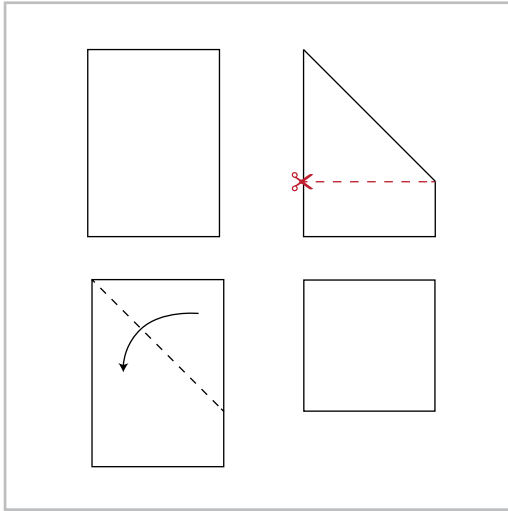

Heart origami

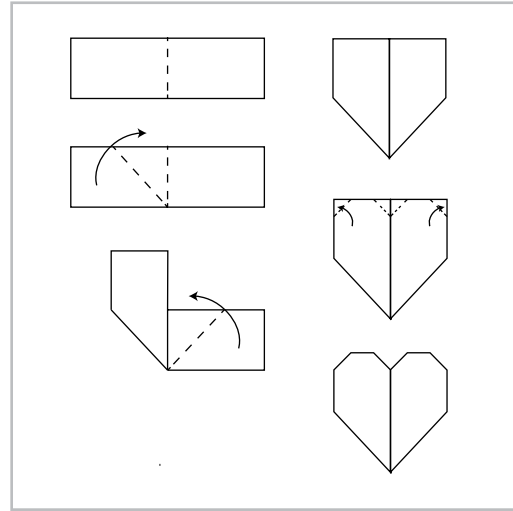

## 1 Snowflakes

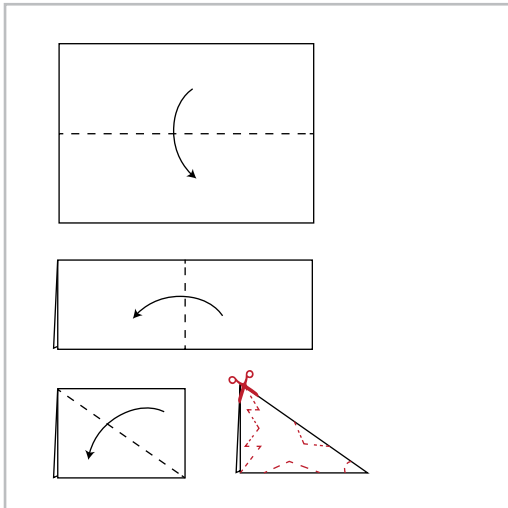

## 2 Migrating Butterflies

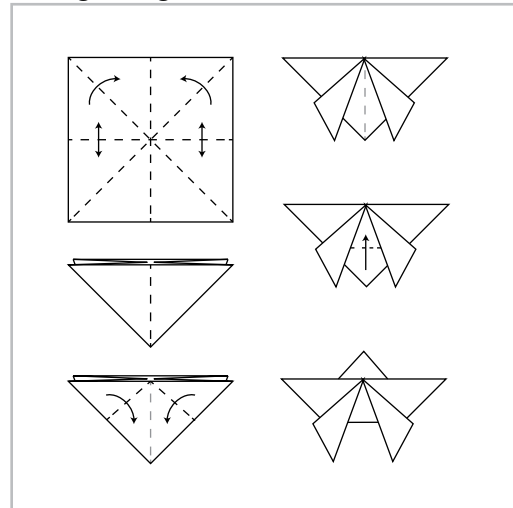

## 3 Curtain Raiser - Put on a Play

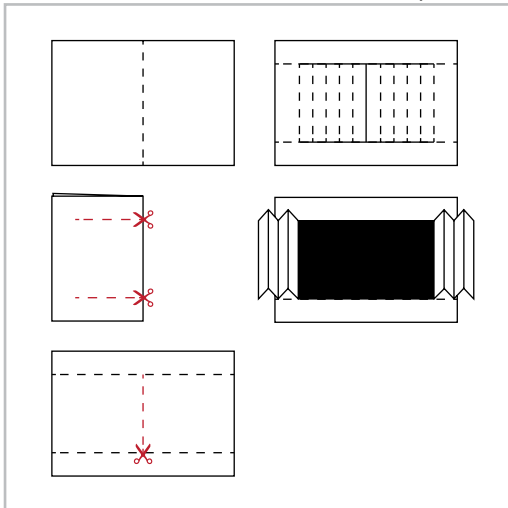

## 4 It's about time - Watches

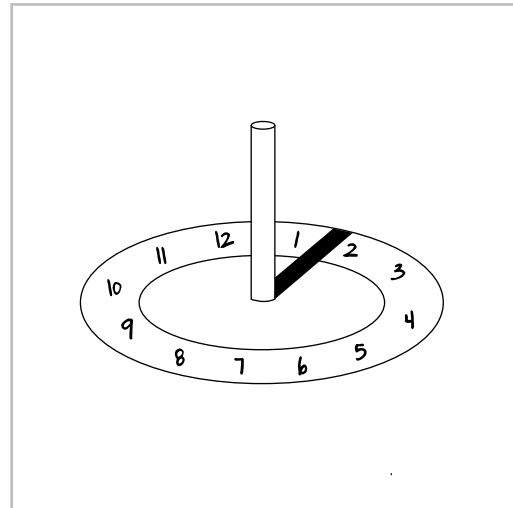

# Appendix

## 5 Singing with the Birds

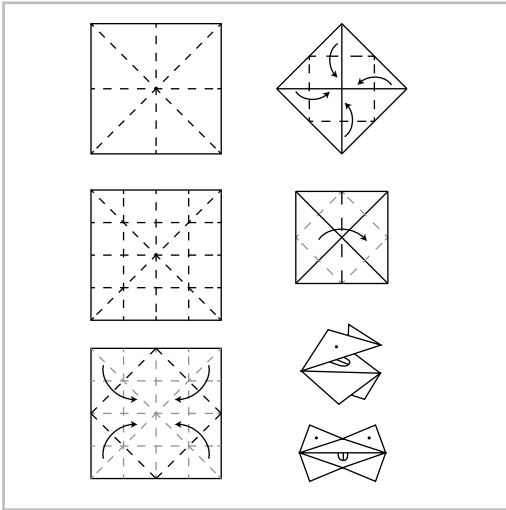

## 6 Write Your Own Fable

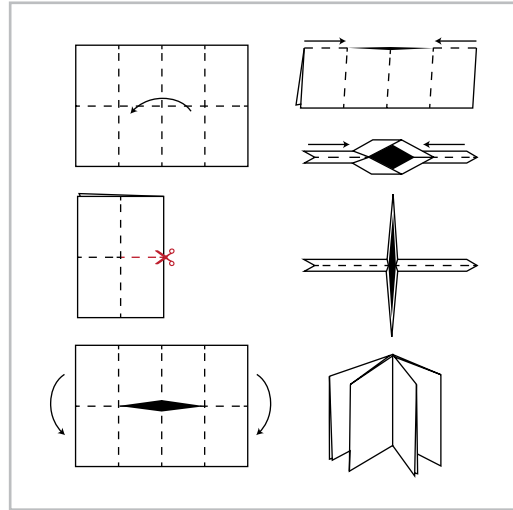

## 7 Paper Forest

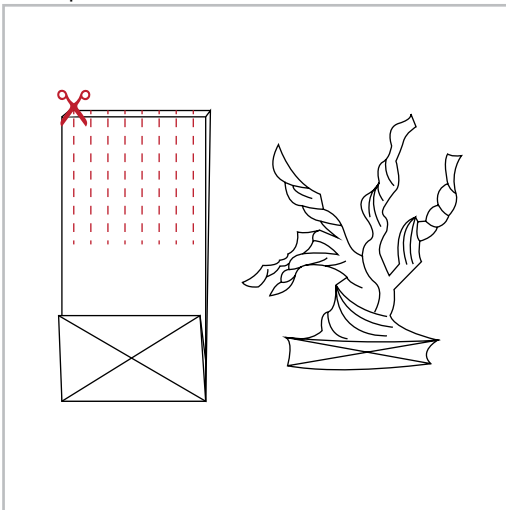

## 8 Chinese New Year Celebration

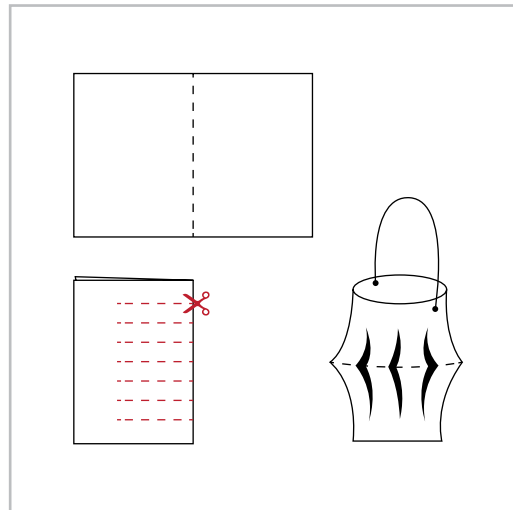

## 9 Save the Frogs

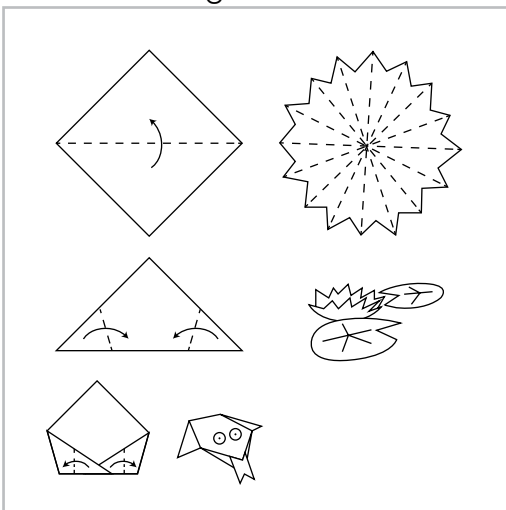

## 10 Out of this World Space Travel

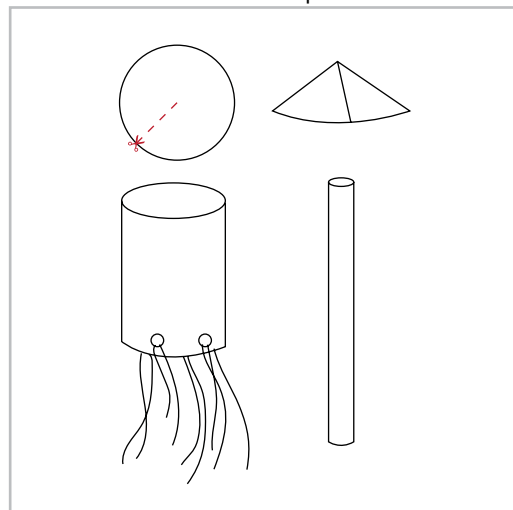

# Appendix

## 11 Be a Star and Shine!

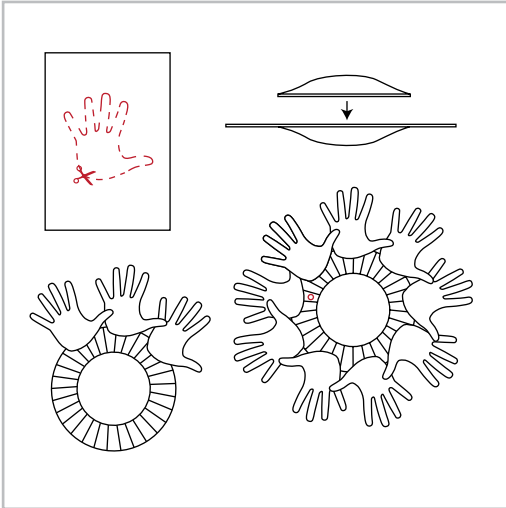

## 12 The Pizza Project

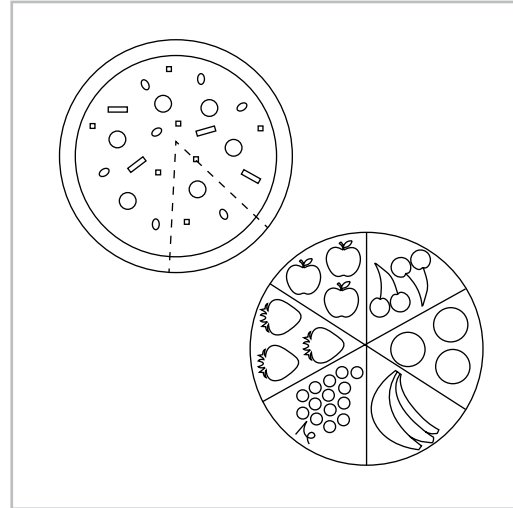

## 13 Flowers Can Talk

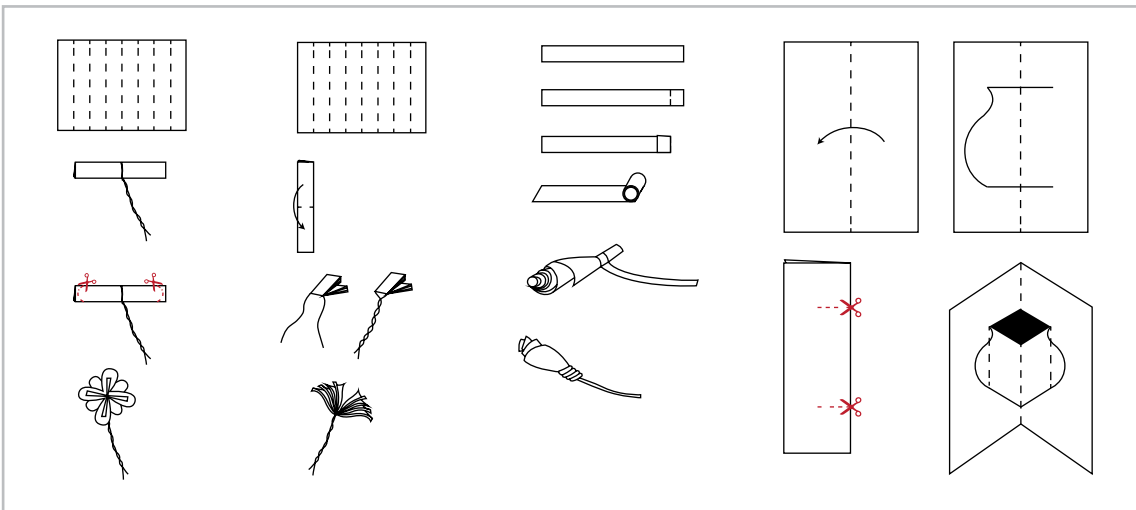

## 14 Everyone is a Winner

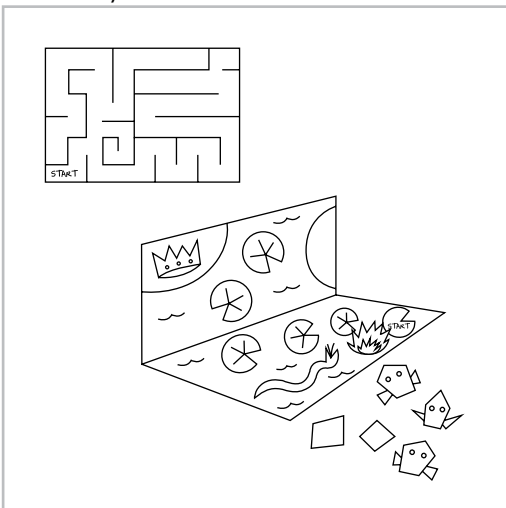

## 15 The Courage to Fly - Bird Nest

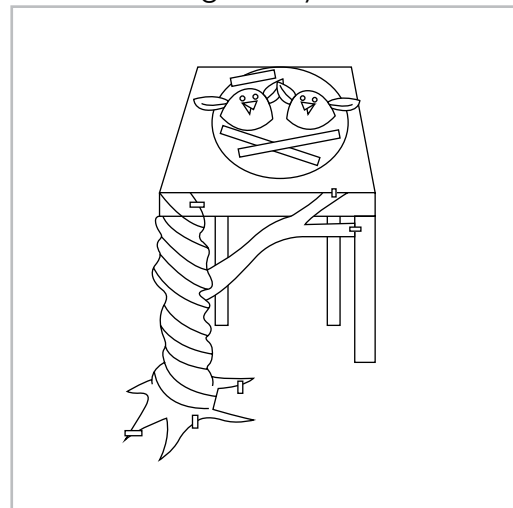

# Appendix

**16** Take Flight - Wings

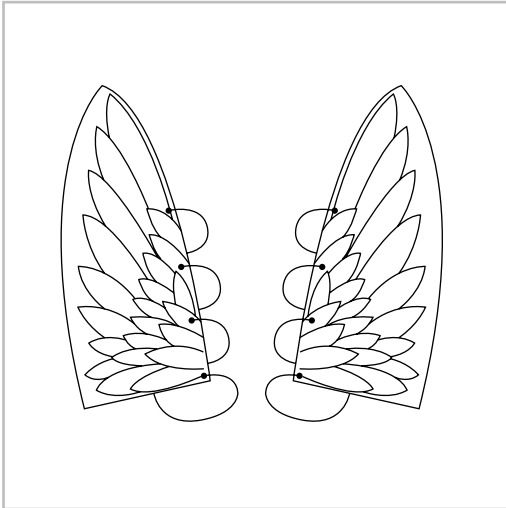

**17** Eye of God

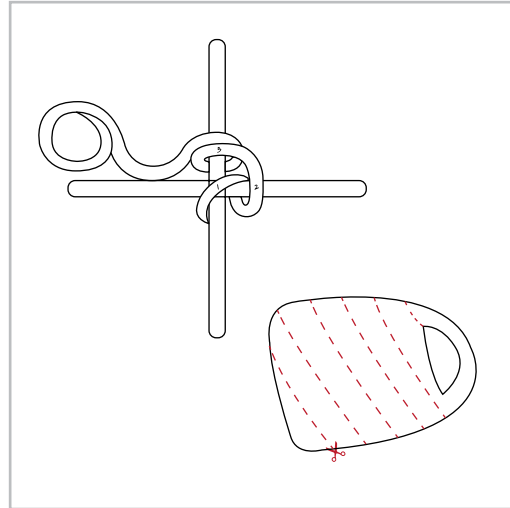

**18** Hide and Seek with Masks

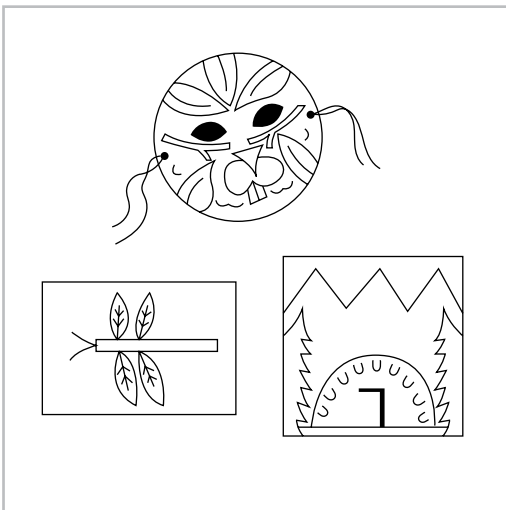

**19** Send Yourself a Message

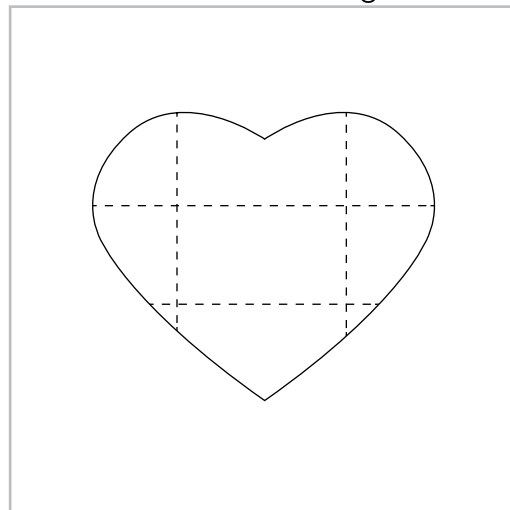

**20** Swim with the Fish

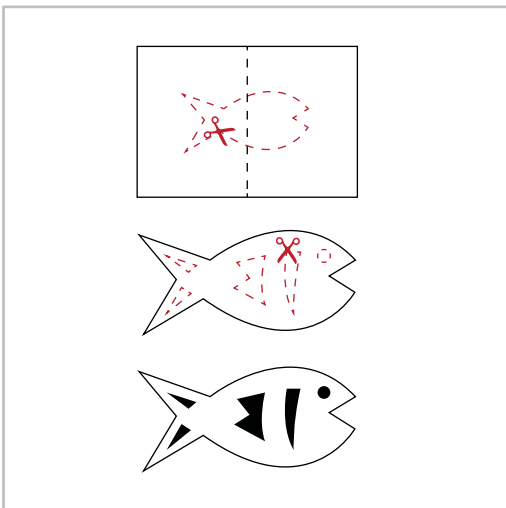



Art Sphere Inc.  
*Teaching Young Lives Through Art*  
Non-Profit 501(c)(3) Organization

**About Us** Art Sphere Inc. (ASI), founded in 1998, provides meaningful art programs for underserved populations in an effort to engage the creativity in communities, empower neighborhoods, explore the positives in peoples' lives, and heal the mind, body, and spirit through art.

Working with hundreds of volunteers every year and partnering with numerous civic and governmental organizations, our grassroots mural painting and park clean-up events help support inner-city neighborhoods. ASI's in-school and after-school workshops lay the framework for art to nourish the character and development of youth, open up a new world of social engagement and reinforce the school curriculum.

**Thank you** for planting the seed of education for future generations to learn and to express their creativity.

## Knight Foundation

The Knight Foundation supports transformational ideas that promote quality journalism, advance media innovation, engage communities and foster the arts. The foundation believes that democracy thrives when people and communities are informed and engaged. For more information, visit [KnightFoundation.org](http://KnightFoundation.org).

**Bartlett Foundation**



*your ideas, flourished.*

Make your vision come to life with compelling, customized designs specialized for all of your marketing and promotional materials.

**LET'S COLLABORATE!**  
[www.BluLotusStudio.com](http://www.BluLotusStudio.com)  
e: [BluLotusStudio@gmail.com](mailto:BluLotusStudio@gmail.com)